



**Farmer
Traktor**

**Front
LOADERS**

Accessories for front loaders

Front loaders (max. capacity: 800-1600 kg) are available for all models of our tractors. Designed for effective loading and unloading of agricultural materials. Great visibility and precision during work.



Gripper for foil wrapped bales
1 cylinder

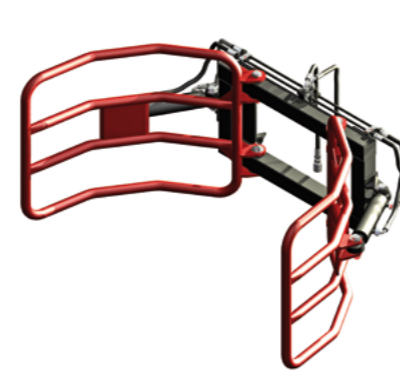

Gripper for foil wrapped bales
2 cylinders Ø 120

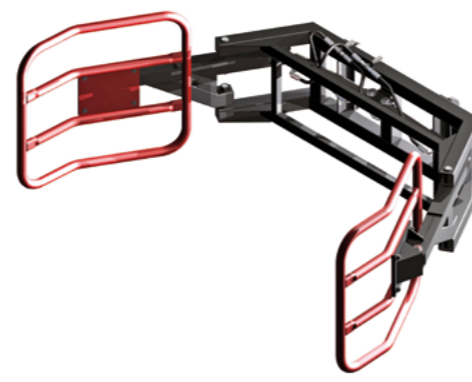

Gripper for foil wrapped bales
2 cylinders Ø 150



Pushing disc with adjustable angle

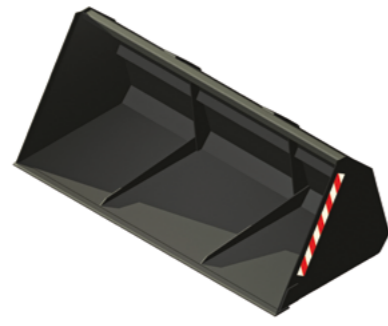

Universal bucket



Bucket with Crocodile

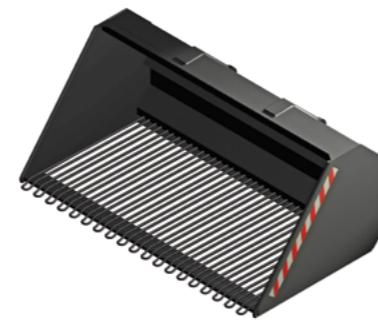

Open root crop bucket



Counterweight



Front LOADERS

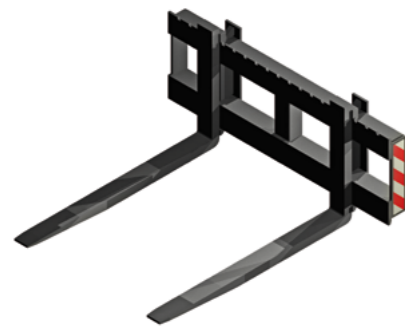

Pallet forks



Pallet forks with fingers for straw bales

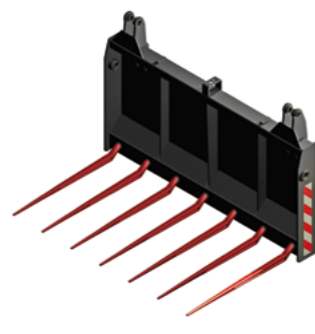

Manure and straw bale forks

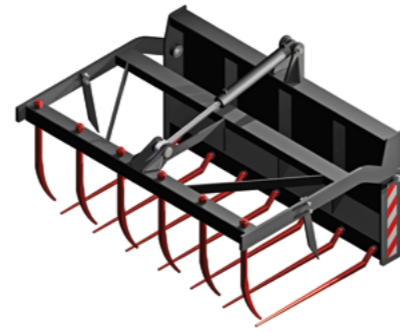

„Crocodile” type silage gripper

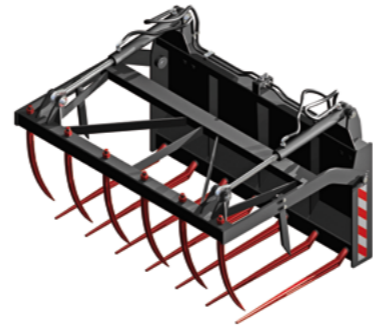

„Crocodile” type silage gripper 2 cylinders

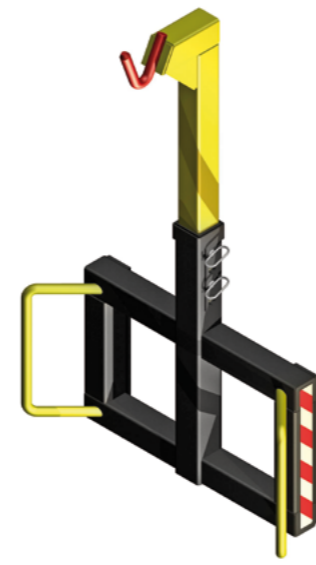

BIG BAG gripper



**Farmer
Traktor**

Farmer Traktor Sp. z o.o. has made every effort to provide accurate information in this brochure, however we reserve the right to change and/or adjust and/or amend specifications, equipment and availability without prior notice. This leaflet cannot be regarded as final, and as such does not constitute an offer for sale of any particular tractor, equipment or so on of specification.

www.farmer.net.pl